



BW™ Gasket for Box Structures





Precast concrete box culverts are used to form relatively large underground storm drains and detention structures for sewer and stormwater management. Typically, a number of manufactured box culvert sections are coupled together end-to-end at a jobsite to form a desired run of a storm drain and/or sewer. Precise alignment and proper coupling of box culverts at a jobsite can be difficult due to the substantial size and weight of the box culvert sections. As a result, the construction of storm drains or detention structures can be challenging and limited to coupling as few as three box culverts per day.

The **BW™ Gasket** provides a seal that can compensate for any misalignment between adjacent box culverts; enables ready coupling of box culverts by reducing the construction time of completed structure; and creates a seal capable of remaining watertight up to 13 psi of hydrostatic water pressure.

The **BW™ Gasket** is a continuous one-piece rubber gasket which is installed in the plant onto the outer peripheral surface of each spigot in such that the gasket encircles the spigot. Thereafter, a pair of box culverts can be coupled together to form a bell-and-spigot joint to compress the gasket and form a watertight seal.

The rear wall of the gasket is notched with an inset groove that extends continuously and circumferentially on the gasket completely about the spigot. This provides the **BW™ Gasket** with mechanical softness which enables the gasket to have a sufficient thickness at a point of maximum compression so that it properly creates a watertight seal without an over-packing condition of the joint.

The endless **BW™ Gasket** is held in place to the outer peripheral surface of the spigot with a rubber based adhesive which ensures the gasket is bonded to the spigot reducing the likelihood that the gasket will be forced out of its proper position during a box culvert coupling process.

Key Advantages

- Meets or exceeds ASTM C-1677
- Compensates for any misalignment between adjacent box culverts
- Enables ready coupling of box culverts, reducing construction time
- Functions on pure compression allowing for fast and easy field installations

Dimensional Data

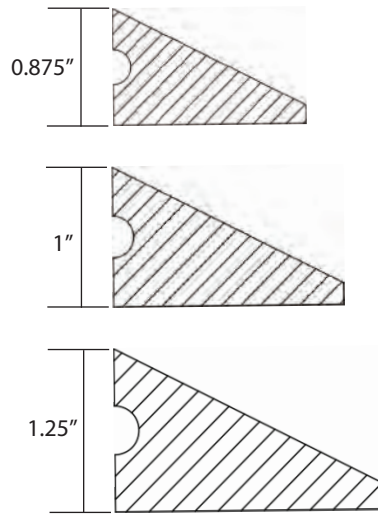

Performance Standard

The **BW™ Gasket** meets or exceeds all material and test requirements listed under the product references section. See the chart below:

Test	Results	ASTM Method
Chemical Resistance 1 N Sulfuric Acid 1 N HCl Acid	No weight loss No weight loss	At 22° for 48h
Tensile Strength	1200 psi or 8.5 MPa, min	D 412
Elongation at Break	350% min.	
Hardness	+/- 5 from mfg's. specified hardness	D 2240
Accelerated Oven-aging	Decr. of 15% max. orig. tensile strength Decr. of 20% max. elongation	D 573
Compression set	Decr. of 25% original deflection	D 395, Method B
Water absorption	Incr. of 10% max. of original by weight	D 471
Ozone resistance	Rating 0	D 1171
Low-temp brittle point	No fracture at -40°C	D 746
Tear resistance	200 lbf/in. or 34 kn/m	D 624, Method B

Copyright ASTM International. Reprinted with permission.

Product References

ASTM C-1677

Standard Specification for Joints for Concrete Box, Using Rubber Gaskets

ASTM C-497

Test Methods for Concrete Pipe, Manhole Sections or Tile

ASTM C-822

Terminology Relating to Concrete Pipe and Related Products

ASTM C-1577

Specification for Precast Reinforced Concrete Monolithic Box Sections for Culverts, Storm Drains and Sewers Designed According to AASHTO LRFD

ASTM C-1619

Specification for Elastomeric Seals for Joining Concrete Structures

In-Plant Installation Instructions

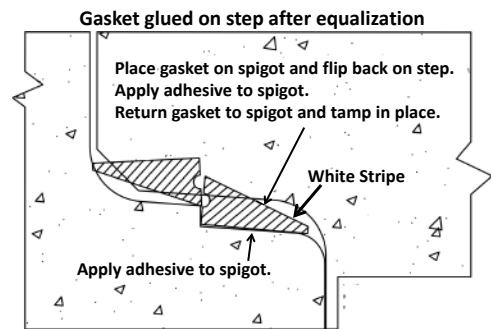

Printing and white stripe must be visible after the gasket is installed. The bottom joint section may need the gasket restrained by C-Clamps, etc. to allow for adequate bonding time of the adhesive system.

Jobsite Installation Instructions

After the **BW™ Gasket** is installed on the spigot and before the box culvert section is coupled to an adjacent section, a gasket lubricant is applied to the outer peripheral sloped wall of the gasket and the bell to reduce the coupling force. Traditionally, a box culvert section with a bell end positioned adjacent a spigot end of a stationary pre-installed box culvert is drawn into engagement with the use of a 6 ton come-along or pipe-puller device. The lubricant ensures the bell of an adjacent box culvert can travel over the spigot and gasket to form a tight bell-to-spigot joint.

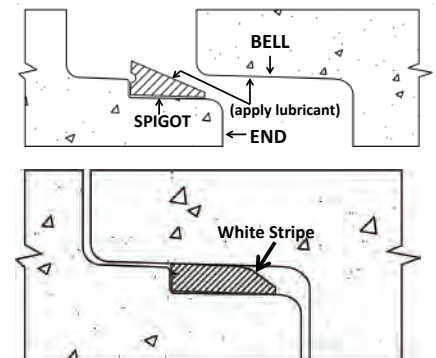

© 2016 Vertex, Inc. Supersedes all previous literature COVERED BY ISSUED AND/OR PENDING PATENTS